

HKS 27m³

3-AXLE TIPPING SEMI-TRAILER



TECHNICAL DATA

Designation	Overall dimensions in mm approx.	Loading area in mm approx.	Loading volume in m ³	GVW in kg	Payload in kg	Coupling height tires in inches in mm approx.	Tilt angle in °
Humbaur HKS	8800x2550x3282	7400x2300x1670	27	36000	29900	1250 385/65R22.5	49

EXECUTION

SAFETY

- SAFETY with disc brakes 430 mm CHASSIS Air
- lift on 1st axle
- Tires of manufacturer's choice
- 6 steel rims – ET 120

BRAKE SYSTEM

- EBS brake system 24 volts with stability program according to ECE directive 2
- interchangeable coupling heads red/yellow at the front ISO 1728
- With paver brake, when operated in the driver's cab (PIN 15)
- Steel air tank

ELECTRICS

- 24 Volt full LED lighting system with LED side marker lights
- Adapter box with 2x7-pin and 15-pin socket
- Full-LED taillights
- 2 LED reversing lights *optional

FRAME

- Chassis frame made of high-quality fine-grain steel in Lightweight construction,
- Coupling plate with 2" kingpin

TROUGH

- 27 m³ U-shaped steel round trough
- Trough base made of wear-resistant, tempered sheet steel HB 450, 5 mm thick
- Side walls made of wear-resistant, tempered sheet steel HB 400 - 1,670 mm
- Swinging rear wall, made of wear-resistant, tempered sheet steel HB 450, with automatic mechanical hook locking

INFORMATION SYSTEMS

- Brake pad wear indicator via warning lamp in the driver's cab
- WABCO Smart Board *optional
- TPMS with Autolocate

SUPPORT

- Steel seat posts with leveling foot, one-side operation

ROOF

- Roll-up roof including tarpaulin with a pivoting crossbar
- Operation via crank and round winding aid
- Roof tarpaulin for roll top 680 g/m²
- Tarpaulin tensioning device with central locking

EQUIPMENT

- Semicircular plastic mudguard
- Contour marking on the side and rear
- 2 wheel chocks with holder
- Holder for shovel and broom
- Plastic tool box 600 x 415 x 460 mm *optional
- Operating platform for roll-up tarpaulin with climbing aid and handrail
- Connection console moved forward

HYDRAULICS

- Hydraulic high pressure hose DN20 with screw coupling HDK BG6
- Front tilt cylinder high and low pressure, max. 250 bar

COLOURING

- Chassis, trough and attachments made of metal, corrosion-protected in 2K Execution: Steel granulate cleaned – primed – 2K commercial vehicle paint (Color of your choice)

HKS

3-AXLE TIPPING SEMI-TRAILER



DIMENSION SKETCH

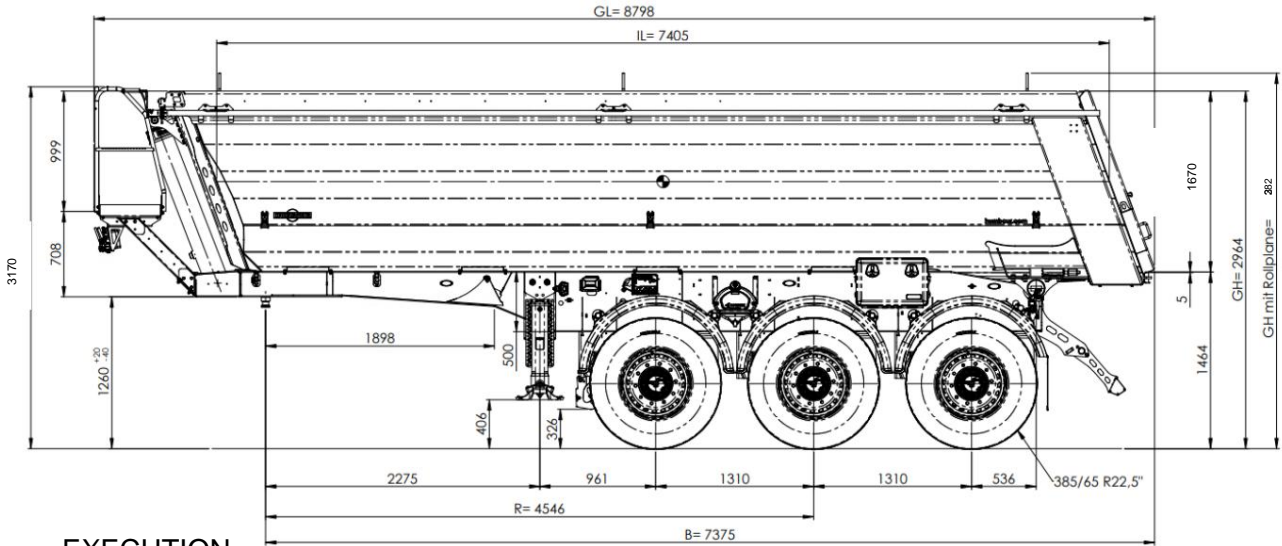

EXECUTION

CHASSIS

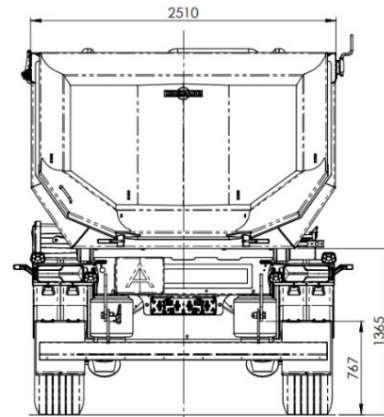
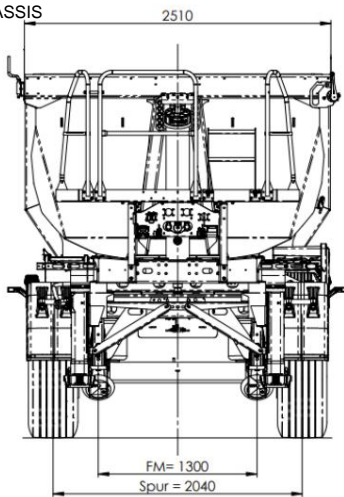

Front turning radius: 1,750 mm, rear turning radius: 2,220 mm, tilt angle: 49°

Subject to technical changes. All dimensions in mm and approximate.



*Safety note! The trailers may only be used in strict compliance with all road traffic, trade association and load securing regulations. All information is provided without guarantee!
No liability is accepted for errors and misprints. Technical changes reserved. All dimensions are approximate and refer to the standard vehicle without accessories.
Additional equipment changes the weight and payload. Images are similar and may contain accessories at an additional cost.